

Pneumatic Actuators

VNE BI SERIES SPECIFICATIONS



EXTRUDED ALUMINUM RACK AND PINION PNEUMATIC ACTUATORS

BI-SERIES

- COMPACT, RELIABLE DESIGN
- OPEN-CLOSED ADJUSTMENT STOPS
- DOUBLE ACTING AND SPRING RETURN
- HIGH-VISIBILITY INDICATOR

STANDARD FEATURES

MAXIMUM PRESSURE RATING

120 PSI/8 BAR

STANDARD TEMPERATURE RATING*

-4°F/-20°C to +180°F/+85°C

MAX/MIN TEMPERATURE RATING**

-40°F/-40°C to +302°F/+150°C

*with standard NBR70 seals

**with Viton or HNBR seals (available upon request)

- 100% FACTORY TESTED
- RACK AND PINION DESIGN FOR CONSISTENT TORQUE OUTPUT
- PRE-LUBRICATED FOR LIFE OF ACTUATOR
- OPTIONAL COATINGS AVAILABLE

MOUNTING OPTIONS

VALVE MOUNTING: ISO 5211 standard base mounting bolt patterns and a double square female output shaft provide multiple options for direct mounting to valve stems and a greater flexibility of actuator rotation. Double D pinions and inserts also are available for additional mounting options.

ACCESSORY MOUNTING: The top mounting pad is drilled and tapped to international NAMUR and ISO standards, providing quick and economical accessory mounting in conjunction with the NAMUR pinion shaft. The standard NAMUR slotted and threaded shaft allows for direct mounting of NAMUR limit switches and valve positioners.

SOLENOID MOUNTING: All VNE actuators have an international NAMUR solenoid mounting pattern for direct mounting of a wide range of solenoid models. The NAMUR mount eliminates the need for pipe nipples or solenoid brackets.

DOUBLE ACTING ACTUATORS

ACTUATOR OVERVIEW

- All listed output torques are expressed in inch pounds of torque (in. lbs.).
- Charts for available air pressure are expressed in pounds per square inch (P.S.I.).
- VNE BI-series actuators offer $\pm 5^\circ$ adjustment in the open and closed positions.

DOUBLE ACTING ACTUATOR SIZING (PLEASE SEE DOUBLE ACTING TORQUE CHART)

1. Establish the valve manufacturer's breakaway or seating/unseating torque, then add 20% as a safety factor (e.g. 115 in. lbs. valve breakaway torque x 20% = 138 in. lbs.).
2. Determine available air pressure to the actuator (e.g. 60 P.S.I.).
3. Refer to the chart, find the 60 P.S.I. column and scan down until a torque value greater than the valve torque is found (e.g. 141 in. lbs.). Then go to the left to determine the VNE model number. In this sample case, the selected actuator would be the BI-52DA.

Contact our sales staff for slurry or steam services.

NOTE: The VNE double acting actuator has no torque drop through the full 90° stroke.

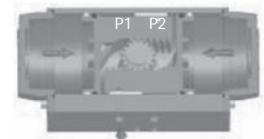

CLOSED

Air to Port 1 (P1) forces the pistons inwards, causing the pinion to turn clockwise.

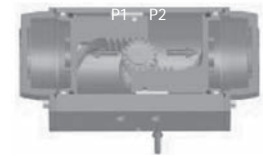

OPEN

Air to Port 2 (P2) forces the pistons outwards, causing the pinion to turn counterclockwise.

SPRING RETURN ACTUATORS

SPRING RETURN ACTUATOR TERMINOLOGY

1. AIR STROKE: When air is supplied to the actuator, the pistons compress the springs. The greater the spring compression, the less torque output the actuator can supply.
2. SPRING STROKE: When air is removed from the actuator, the stored energy in the springs forces the pistons inward. At full compression, the spring is at its maximum torque output. This is the SPRING START. When springs are uncompressed, this is the SPRING END.
3. FAIL POSITION: Standard VNE actuators are preset for fail closed (SR) operation, but can be adjusted easily for fail open (SO) rotation.

SPRING RETURN ACTUATOR SIZING (PLEASE SEE SPRING RETURN TORQUE CHART)

1. Establish the valve manufacturer's seating torque (closing) and breakaway torque (opening). Add a 20% safety factor (e.g. a valve torque of 80 in. lbs. x 20% = 96 in. lbs.).
 2. Refer to the spring torque column and select the SPRING END TORQUE that equals or exceeds the required valve torque (i.e. the VNE model BI-63-SR with a 80# spring set, which has an spring end of 111 in. lbs. and a spring start of 196 in. lbs.).
 3. Determine the available air line pressure to the actuator (e.g. 80 P.S.I.). Refer to the 80 P.S.I. column and scan down to where it intersects with the BI-63-SR with an 80# spring. In this case, the end spring torque is 111 in. lbs., which exceeds the required 96 in. lbs. required.
- Contact our sales staff for slurry or steam services.

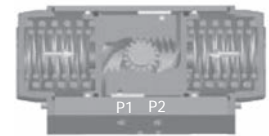

CLOSED

Loss of air pressure on Port 2 causes springs to drive the pistons inward. The pinion turns clockwise to close while air exhausts from Port 2.

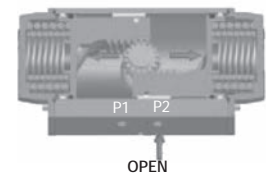

OPEN

Air to Port 2 (P2) forces the pistons outwards, causing the springs to compress. The pinion turns counterclockwise.

VNE BI SERIES PNEUMATIC ACTUATOR FEATURES

PINION

The hardened steel pinion is precision ground and then nickel plated in order to reduce friction, provide maximum wear resistance, and protect against corrosion under severe conditions. An optional stainless steel pinion is available for corrosive environments.

ACTUATOR BODY

The aluminum extrusion is hard anodized to 45-50 microns to protect against wear and corrosion while reducing piston friction to the absolute minimum.

HEAVY DUTY SPRINGS

True-rated spring sets create absolute confidence in all of the fail safe spring return models. The high tensile steel springs are coated with zinc phosphate for corrosion resistance. Springs can be safely and quickly modified into sets ranging from 40 pounds to 80 pounds (through 120 pounds on 200/270 models). Full length end cap bolts allow for easy and safe disassembly.

ANTI-BLOWOUT SYSTEM

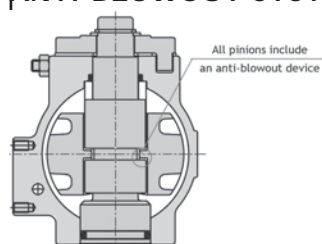

INDICATOR

A dome indicator is standard on the BI-52 through BI-125 models. A high visibility open-closed dome indicator is available on all VNE actuators.



ROTATION ADJUSTMENT

Standard adjustment is $\pm 5^\circ$ in both the open and closed positions through easily accessible external adjustment screws.

END CAPS

Epoxy coated die cast aluminum end caps provide maximum resistance against potentially corrosive elements.

PISTON GUIDES

Large contact areas and self-lubricating, highly-durable materials provide high thrust stability with minimum friction.

PINION SEALS

NBR-70 rubber pinion seals provide trouble-free operation at standard temperature ranges. Viton® and HNBR seals are available to high or low temperature extremes.

PISTONS

The precisely-balanced die cast aluminum pistons are fitted with high-quality rings and guides, resulting in high ratios of output torque vs. input air pressure. The twin rack and piston design creates a constant torque output on all models.

CE APPROVED

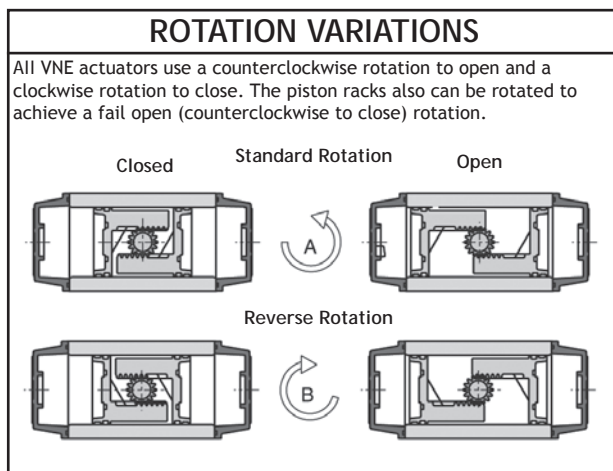

OPTION FOR CORROSIVE ENVIRONMENTS

ALL 316 STAINLESS STEEL ACTUATORS ALSO AVAILABLE. PLEASE CONTACT OUR SALES STAFF FOR INFORMATION.

SPRING COMBINATION OPTIONS

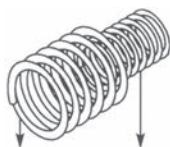

BI-52SR TO BI-145SR			
EXTERNAL SPRING	INTERNAL SPRING	AIR SUPPLY	SET #
1	1	40PSI	01
2	X	50PSI	02
1	2	60PSI	03
2	1	70PSI	04
2	2	80PSI	05

BI-161 TO BI-271SR					
SPRINGS PER SIDE	AIR SUPPLY	SET #	SPRINGS PER SIDE	AIR SUPPLY	SET #
2/3	40PSI	01	4/5	80PSI	05
3/3	50PSI	02	5/5	100PSI	06
3/4	60PSI	03	5/6	110PSI	07
4/4	70PSI	04	6/6	120PSI	08

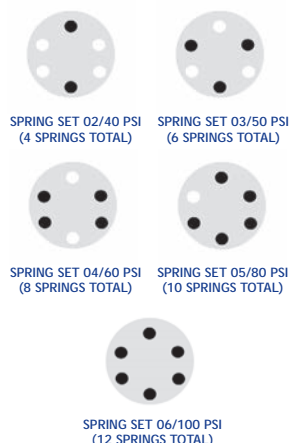

VNE BI SERIES DIMENSIONAL DATA

FOR ACTUATOR MODELS
BI-52 THROUGH BI-145

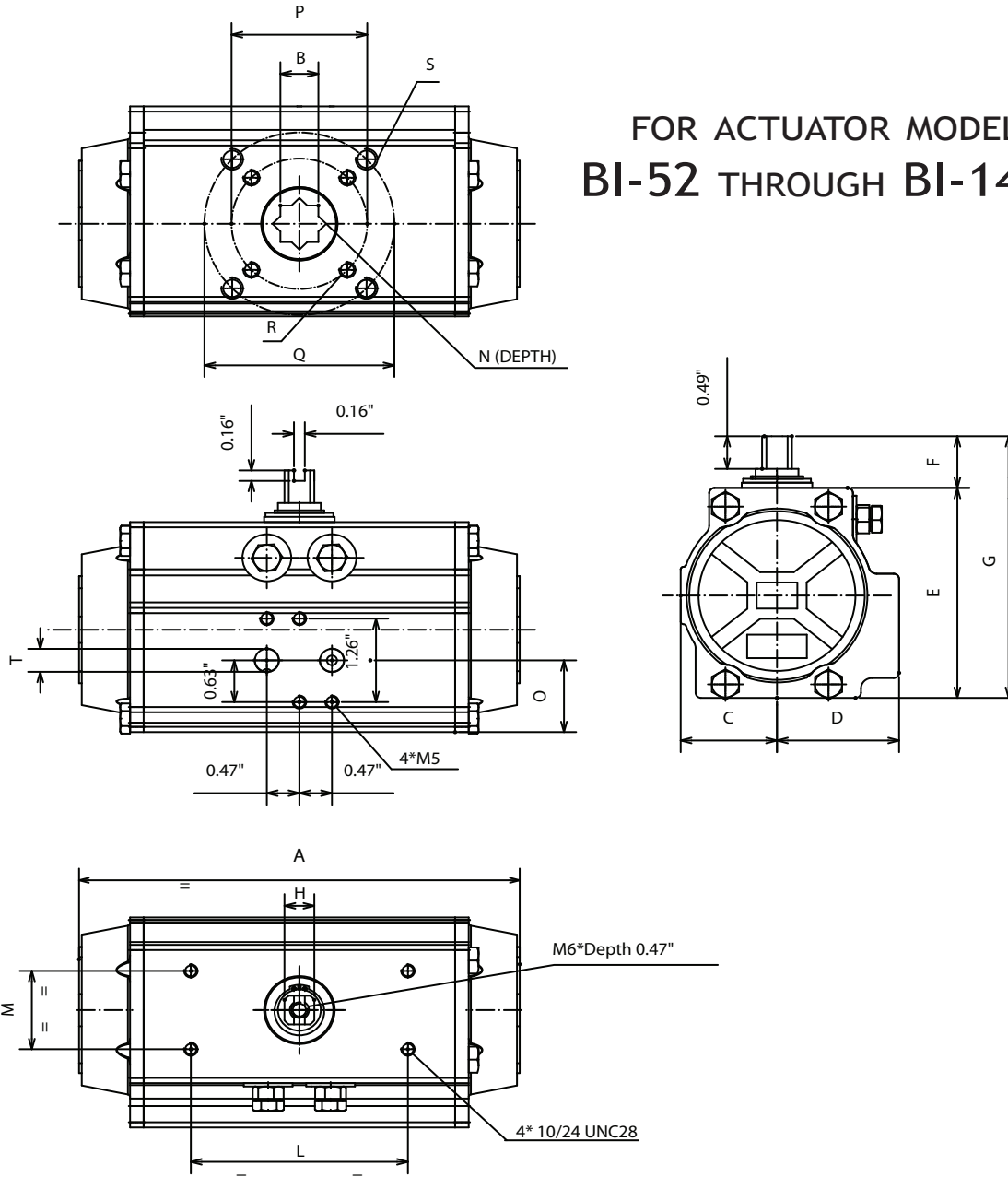

	ISO 5211	A	B	C	D	E	F	G	H	L	M	N	O	P	Q	R (UNC)	S (UNC)	T (NPT)
BI-52	F03/F05	5.49	0.43	1.18	1.61	2.74	0.79	3.52	0.43	3.15	1.18	0.47	1.04	1.42	1.97	10-24 X 0.35	1/4-20 X 0.35	1/8"
BI-63	F05/F07	6.38	0.55	1.40	1.77	3.17	0.79	3.96	0.43	3.15	1.18	0.63	1.08	1.97	2.76	1/4-20 X 0.31	5/16-18 X 0.47	1/8"
BI-75	F05/F07	8.15	0.67	1.65	2.07	3.82	0.79	4.61	0.67	3.15	1.18	0.75	1.38	1.97	2.76	1/4-20 X 0.31	5/16-18 X 0.47	1/8"
BI-88	F05/F07	9.65	0.67	1.93	2.36	4.55	0.79	5.33	0.67	3.15	1.18	0.75	1.81	1.97	2.76	1/4-20 X 0.31	5/16-18 X 0.47	1/8"
BI-100	F07/F10	10.69	0.67	2.17	2.68	4.78	0.79	5.57	0.67	3.15	1.18	0.81	1.97	2.76	4.02	5/16-18 x 0.31	3/8-16 x 0.55	1/4"
BI-115	F07/F10	12.91	0.87	2.52	2.87	5.57	1.18	6.75	1.06	5.12	1.18	0.94	1.97	2.76	4.02	5/16-18 x 0.47	3/8-16 x 0.55	1/4"
BI-125	F07/F10	14.41	0.87	2.68	3.15	6.04	1.18	7.22	1.06	5.12	1.18	0.94	2.40	2.76	4.02	5/16-18 x 0.47	3/8-16 x 0.59	1/4"
BI-145	F10/F12	15.79	1.06	3.09	3.54	7.05	1.18	8.23	1.06	5.12	1.18	0.94	2.87	4.02	4.92	3/8-16 x 0.59	1/2-13 x 0.71	1/4"

VNE BI SERIES DIMENSIONAL DATA

MODEL BI-32DA

*Actuator does not accept namur direct mount solenoid. Please use the next size up actuator for direct mount solenoid applications.

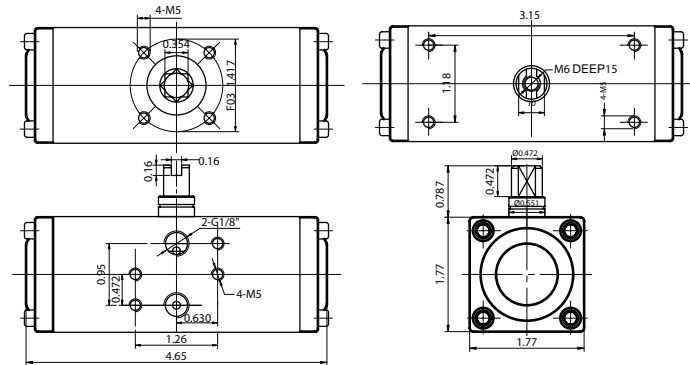

MODELS BI-161 THROUGH BI-271

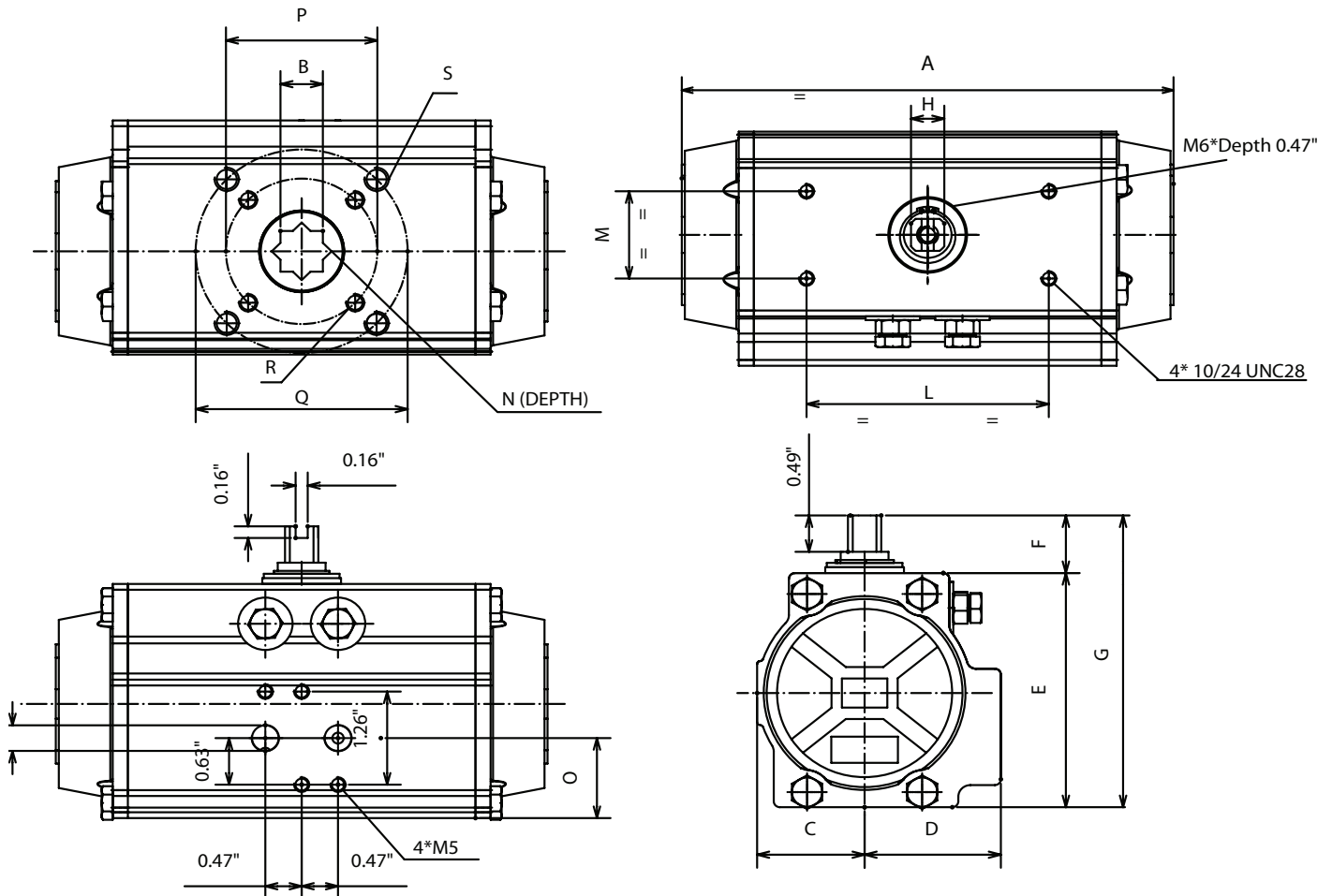

	ISO 5211	A	B	C	D	E	F	G	H	K	L	M	N	O	P	Q	R (UNC)	S (UNC)	T (NPT)
BI-161	F10-F12	16.93	1.06	3.41	3.94	7.56	1.18	8.74	1.06	---	5.12	1.18	1.14	3.29	4.02	4.92	3/8-16*.059	1/2-13*.071	1/4
BI-181	F14	18.98	1.42	4.02	4.02	8.74	1.18	9.92	1.18	---	5.12	1.18	1.54	2.36	5.51	---	5/8-11*.098	---	1/4
BI-201	F14	20.94	1.42	4.41	4.41	9.61	1.18	10.79	1.18	---	5.12	1.18	1.54	2.48	5.51	---	5/8-11*.098	---	1/4
BI-241	F16	26.06	1.81	5.24	5.24	11.34	1.18	12.52	1.18	---	5.12	1.18	1.93	3.35	6.50	---	3/4-10*1.18	---	1/4
BI-271	F16	28.74	1.81	6.02	6.02	12.72	1.18	13.90	1.18	---	5.12	1.18	1.93	4.17	6.50	---	3/4-10*1.18	---	1/4

VNE BI SERIES DOUBLE ACTING ACTUATOR TORQUE

AVAILABLE AIR SUPPLY PRESSURE (PSI)

MODEL	40PSI	50PSI	60PSI	70PSI	80PSI	90PSI	100PSI	115PSI
BI-32-DA	34	43	55	64	71	82	87	101
BI-52-DA	86	110	133	156	179	203	226	261
BI-63-DA	154	196	238	280	321	363	405	468
BI-75-DA	284	360	435	511	586	661	737	850
BI-88-DA	405	486	607	767	848	928	1089	1250
BI-100-DA	646	818	991	1163	1336	1508	1681	1939
BI-115-DA	1070	1355	1640	1925	2210	2495	2780	3208
BI-125-DA	1409	1783	2157	2532	2906	3280	3654	4216
BI-145-DA	1920	2310	3080	3850	4230	4620	5390	6160
BI-161-DA	2513	3009	4018	5018	5523	6027	7027	8036
BI-181-DA	3390	4262	5425	6780	7452	8134	9488	10842
BI-201-DA	4708	5846	7532	9417	10356	11294	13179	15064
BI-241-DA	10267	12325	16436	20543	22596	24650	28757	32863
BI-271-DA	13719	16462	21950	27438	30182	32926	38422	43910

ACTUATOR TORQUE OUTPUT (IN. LBS.)

FOR TORQUE VALUES OR AIR SUPPLY PRESSURES NOT LISTED, PLEASE CONSULT FACTORY

VNE BI SERIES TECHNICAL DATA

ACTUATOR WEIGHTS (LBS.)

MODEL	32	52	63	75	88	100	115	125	145	161	181	201	241	271
DOUBLE ACTING	1.08	2.25	3.26	5.51	9.24	11.02	17.75	22.09	33.86	46.91	59.00	80.80	132.30	189.61
SPRING RETURN	---	2.62	3.97	6.94	10.34	14.40	23.92	26.76	45.28	65.04	70.50	94.30	154.30	227.10

ACTUATOR CYCLE TIME (SECONDS)

MODEL	32	52	63	75	88	100	115	125	145	161	181	201	241	271
DOUBLE ACTING	0.03	0.03	0.06	0.12	0.20	0.30	0.53	0.83	0.98	1.15	1.45	1.74	3.34	4.50
DOUBLE ACTING	0.03	0.04	0.08	0.12	0.19	0.27	0.47	0.66	0.93	1.10	1.38	1.70	3.30	4.50
SPRING RETURN	---	0.09	0.14	0.22	0.31	0.44	0.83	1.08	1.23	1.75	2.10	2.38	3.82	4.50
SPRING RETURN	---	0.09	0.14	0.22	0.33	0.46	0.78	0.90	0.97	1.34	1.79	2.19	4.50	6.20

NOTE: ALL CYCLE TIMES ARE DERIVED INDEPENDENTLY OF VALVES AND ACTUATOR ACCESSORIES THAT MIGHT AFFECT OVERALL TIME PERFORMANCE.
CYCLE TIMES ARE BASED ON 80 PSI AIR SUPPLY.

ACTUATOR AIR CONSUMPTION (CUBIC INCHES)

MODEL	32	52	63	75	88	100	115	125	145	161	181	201	241	271
Double acting (both ways)	4.03	15.93	29.35	36.73	81.77	112.1	164.76	255.32	390.55	510.65	742.81	947.82	1479.66	2001.59
Spring Return	---	7.69	14.22	17.15	36.00	54.37	85.43	122.05	165.98	215.11	348.84	462.56	747.22	945.87

VNE BI SERIES SPRING RETURN ACTUATOR TORQUE

ACTUATOR TORQUE OUTPUT (IN. LBS.)

MODEL	SPRING SET	SPRING TORQUE START-END	40PSI AIR TORQUE START-END	50PSI AIR TORQUE START-END	60PSI AIR TORQUE START-END	70PSI AIR TORQUE START-END	80PSI AIR TORQUE START-END	90PSI AIR TORQUE START-END	100PSI AIR TORQUE START-END	115PSI AIR TORQUE START-END
BI-52-SR	01	44-32	48-23	72-47	95-70					
	02	59-42		61-31	85-54	108-77				
	03	66-46			80-47	104-70	127-94	150-117		
	04	82-57			70-31	93-55	116-78	140-101	163-125	
	05	105-72				78-32	101-55	125-78	148-102	183-137
BI-63-SR	01	85-44	92-38	134-80	176-122					
	02	109-58		120-56	162-98	204-140				
	03	128-71			149-79	191-121	233-162	275-204		
	04	152-82			136-54	177-96	219-138	261-180	303-222	
	05	196-111				151-53	193-95	235-136	276-178	339-241
BI-75-SR	01	172-89	168-63	244-138	319-214					
	02	226-118		215-85	291-160	366-235				
	03	249-133			275-137	351-212	426-288	502-363		
	04	303-162			247-83	322-158	398-234	473-309	549-385	
	05	380-205				279-81	354-157	430-232	505-308	618-421
BI-88-SR	01	242-142	196-67	277-147	438-308					
	02	298-176		244-91	404-251	566-412				
	03	361-215			366-189	526-350	606-430	687-510		
	04	416-248			332-133	493-293	573-373	653-454	814-614	
	05	536-321				420-173	501-254	581-335	742-495	902-656
BI-100-SR	01	395-218	384-154	556-326	728-499					
	02	521-288		485-199	658-372	830-544				
	03	564-318			628-329	801-502	973-674	1146-847		
	04	691-389			558-203	730-375	903-548	1075-720		
	05	860-486				630-206	802-378	975-551	1147-723	1406-982
BI-115-SR	01	658-363	650-270	935-555	1220-840					
	02	835-449		848-378	1133-663	1419-949				
	03	957-538			1044-541	1329-827	1615-1112	1900-1397		
	04	1133-625			958-365	1243-650	1528-934	1813-1220	2098-1505	
	05	1432-800				1067-352	1352-637	1638-922	1923-1207	2350-1635
BI-125-SR	01	877-470	850-328	1224-703	1599-1077					
	02	1040-560		1135-539	1509-914	1883-1288				
	03	1313-718			1351-640	1725-1015	2099-1389	2474-1763		
	04	1477-808			1261-477	1636-851	2010-1226	2384-1600	2758-1974	
	05	1913-1055				1388-415	1762-789	2136-1164	2511-1538	3072-2099

VNE BI SERIES SPRING RETURN ACTUATOR TORQUE

ACTUATOR TORQUE OUTPUT (IN. LBS.)

MODEL	SPRING SET	SPRING TORQUE START-END	40PSI AIR TORQUE START-END	50PSI AIR TORQUE START-END	60PSI AIR TORQUE START-END	70PSI AIR TORQUE START-END	80PSI AIR TORQUE START-END	90PSI AIR TORQUE START-END	100PSI AIR TORQUE START-END	115PSI AIR TORQUE START-END
BI-145-SR	01	1345-725	1053-319	1461-681	2142-1407					
	02	1522-814		1319-496	2044-1221	2770-1947				
	03	361-248			1814-761	2540-1487	2903-1850	3266-2213		
	04	2124-1132			1708-566	2434-1292	2797-1655	3168-2027	3894-2752	
	05	2725-1451				2106-637	2469-1009	2832-1372	3558-2097	4283-2823
BI-161-SR	03	1761-1195	1823-1247	2823-2257	3832-3257	4238-3761				
	04	2354-1593		2425-1663	3434-2080	3928-3168	4434-3673	5443-4673		
	05	2938-1983			3035-2080	3540-2584	4036-3089	5045-4089	6045-5089	
	06	3531-2380				3142-1991	3637-2496	4646-3505	5647-4505	
BI-181-SR	03	2514-1681	2390-1549	3744-2912	5098-4266	5779-4939				
	04	3354-2293		3186-2071	4540-3425	5213-4107	5895-4779	7249-6133		5475-3865
	05	4195-2796			3982-2584	4655-3266	5337-3939	6691-5302	8045-6656	
	06	5027-3355				4098-2425	4779-3107	6133-4461	7488-5815	
BI-201-SR	03	3345-2257	3390-2301	5275-4186	7152-6072	8099-7010				
	04	4461-3009		4523-3071	6399-4956	7346-5895	8284-6833	10170-8718		
	05	5576-3762			5646-3841	6593-4779	7532-5717	9417-7603	11130-9480	
	06	6691-4514				5841-3664	6780-4602	8665-6487	10550-8373	10562-8137
BI-241-SR	03	7452-4983	7346-4868	11453-8975	15560-13082	17613-15135				
	04	9939-6638		9798-6488	13905-10603	15958-12657	18012-14710	22193-18817		
	05	12427-8293		8143-4010	12250-8116	14303-10169	16357-12213	20463-16330	24570-20437	
	06	14914-9949			14896-7922	17791-10807	20676-13701	26456-19472	32226-25252	
BI-271-SR	03	10479-6992	10338-6850	16117-12630	21888-18401	24783-21295				
	04	13976-9329		13781-9134	19560-14905	22446-17799	25340-20685	31111-26464		
	05	17472-11657		11453-5638	17233-11418	20118-14303	23004-17188	28783-22968	34563-28748	
	06	20968-13984			14896-7922	17790-10807	20676-13701	26455-19472	32226-25252	27115-20965

VNE BI-32-DA PARTS BREAKDOWN

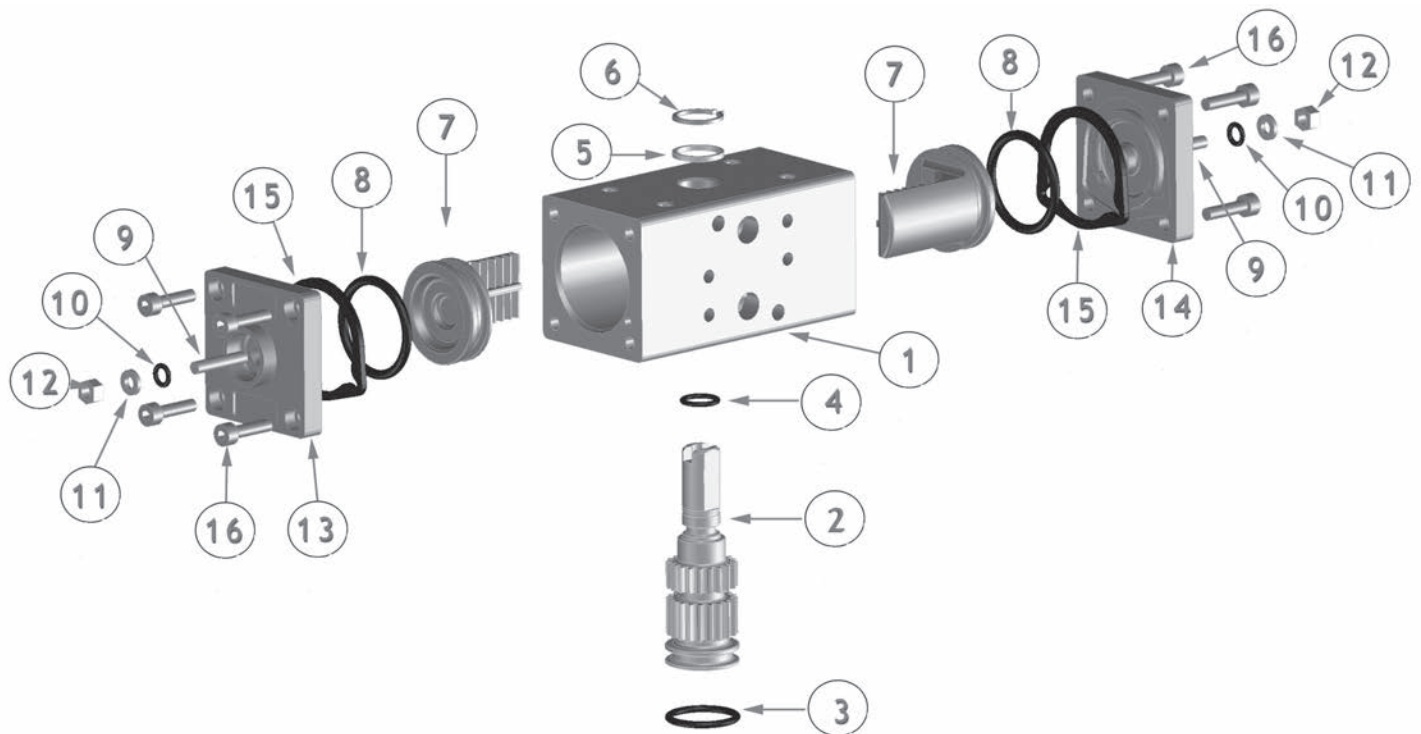

PART NUMBER	DESCRIPTION	MATERIAL	TREATMENT	QTY. (DA)
1	BODY	EXTRUDED ALUMINUM	HARD ANODIZED	1
2	ANTI-BLOWOUT PINION	STEEL	NICKEL PLATED	1
3	LOWER PINION O-RING*	NBR70	---	1
4	TOP PINION O-RING	NBR70	---	1
5	PINION SPACER RING*	PTFE+15% GRAPHITE	---	1
6	PINION SNAP RING	STEEL	NICKEL PLATED	1
7	PISTON	DIE CAST ALUMINUM	---	1
8	PISTON O-RING*	NBR70	---	2
9	STOP BOLT	STAINLESS STEEL	---	2
10	STOP BOLT O-RING*	NBR70	---	2
11	STOP BOLT WASHER	STAINLESS STEEL	---	2
12	STOP BOLT RETAINING NUT	STAINLESS STEEL	---	2
13	LEFT END CAP	DIE CAST ALUMINUM	EPOXY COATED	1
14	RIGHT END CAP	DIE CAST ALUMINUM	EPOXY COATED	1
15	END CAP SEAL	NBR70	---	2
16	END CAP BOLT	STAINLESS STEEL	---	8

*Parts subject to wear

VNE BI-52 THROUGH BI-145 PARTS BREAKDOWN

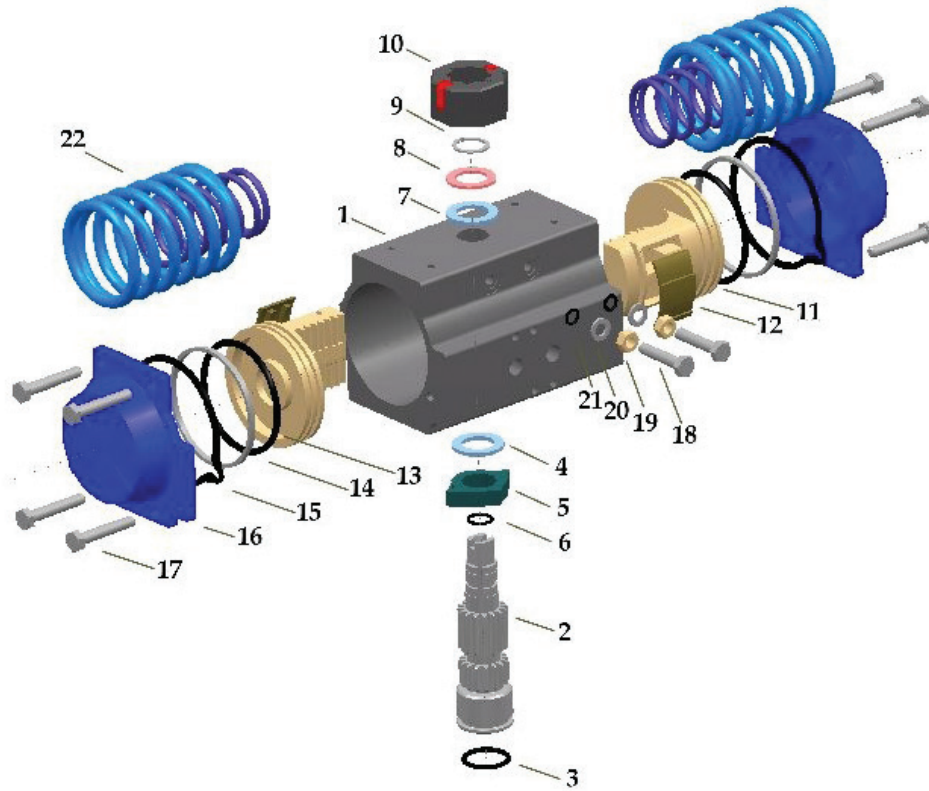

PART NUMBER	DESCRIPTION	MATERIAL	TREATMENT	QTY. (DA)	QTY. (SR)
1	BODY	EXTRUDED ALUMINUM	HARD ANODIZED	1	1
2	ANTI-BLOWOUT PINION	STEEL	NICKEL PLATED	1	1
3	LOWER PINION O-RING*	NBR70	---	1	1
4	PINION SPACER RING	PTFE+15% GRAPHITE	---	1	1
5	TOP PINION O-RING	NBR70	---	1	1
6	CAM SPACER RING*	PTFE+15% GRAPHITE	---	1	1
7	STOP ADJUSTMENT	STAINLESS STEEL	---	1	1
8	POSITION INDICATOR	NYLON	---	1	1
9	PINION WASHER	STAINLESS STEEL	---	1	1
10	PINION SNAP RING	STEEL	NICKEL PLATED	1	1
11	PISTON	DIE CAST ALUMINUM	---	2	2
12	PISTON O-RING*	NBR70	---	2	2
13	ANTI-FRICTION RING*	PTFE+15% GRAPHITE	---	2	2
14	PISTON THRUST BLOCK	PTFE+15% GRAPHITE	---	2	2
15	STOP BOLT WASHER	STAINLESS STEEL	---	2	2
16	STOP BOLT	STAINLESS STEEL	---	2	2
17	EXTERNAL SPRING	STEEL	ZINC PHOSPHATE COATED	N/A	SEE SPRING CHART
18	INTERNAL SPRING	STEEL	ZINC PHOSPHATE COATED	N/A	SEE SPRING CHART
19	END CAP	DIE CAST ALUMINUM	EPOXY COATED	1	1
20	STOP WASHER				
21	END CAP SEALS	NBR70	---	8	8
22	END CAP BOLTS	STAINLESS STEEL	---	8	8

*Parts subject to wear

VNE BI-161 THROUGH BI-271 PARTS BREAKDOWN

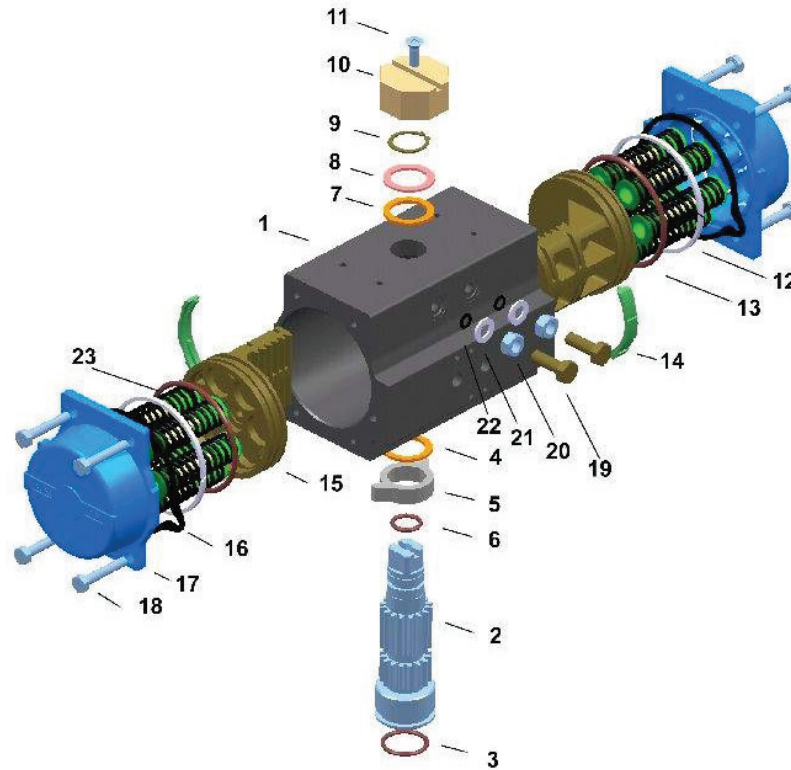

PART NUMBER	DESCRIPTION	MATERIAL	TREATMENT	QTY. (DA)	QTY. (SR)
1	BODY	EXTRUDED ALUMINUM	HARD ANODIZED	1	1
2	ANTI-BLOWOUT PINION	NICKEL PLATED STEEL	NICKEL PLATED	1	1
3	LOWER PINION O-RING*	NBR70 OR VITON	---	1	1
4	PINION SPACER RING	POM	---	1	1
5	STOP ADJUSTMENT	STAINLESS STEEL	---	1	1
6	TOP PINION O-RING	NBR70 OR VITON	NICKEL PLATED	1	1
7	CAM SPACER RING*	POM	NICKEL PLATED	1	1
8	PINION WASHER	STAINLESS STEEL	---	2	2
9	PINION SNAP RING	STAINLESS STEEL	---	2	2
10	POSITION INDICATOR	NYLON	---	2	2
11	INDICATOR BOLT	NYLON+SS	---	2	2
12	ANTI-FRICTION RING*	POM	---	2	2
13	PISTON O-RING*	NBR70 OR VITON	---	2	2
14	PISTON THRUST BLOCK	POM	---	2	2
15	PISTON	DIE CAST ALUMINUM	ZINC PHOSPHATE COATED	N/A	SEE SPRING CHART
16	END CAP SEALS	NBR70 OR VITON	ZINC PHOSPHATE COATED	N/A	SEE SPRING CHART
17	END CAP	DIE CAST ALUMINUM	ZINC PHOSPHATE COATED	N/A	SEE SPRING CHART
18	END CAP BOLTS	STAINLESS STEEL	EPOXY COATED	1	1
19	STOP BOLT	STAINLESS STEEL	EPOXY COATED	1	1
20	STOP NUT	STAINLESS STEEL	---	8 (160-201) 12 (271)	8 (160-201) 12 (271)
21	STOP BOLT WASHER	STAINLESS STEEL	---	2	2
22	STOP BOLT O-RING*	NBR70 OR VITON	---	2	2
23	SPRING SETS	ZINC COATED STEEL	ZINC PHOSPHATE COATED	---	12 (271 ONLY)

*Parts subject to wear

VNE BI-SS PNEUMATIC ACTUATOR FEATURES

STAINLESS STEEL BODY

The all-SS housing is ideal for sanitary, pulp and paper, marine and a variety of other applications where corrosion-resistance is crucial.

HEAVY-DUTY PINION

The one-piece stainless steel alloy shaft has precision machined gear teeth for precise operations.

BEARINGS

Replacable top and bottom TFE pinion bearings ensure low friction, stability up to 400° F and corrosion resistance.

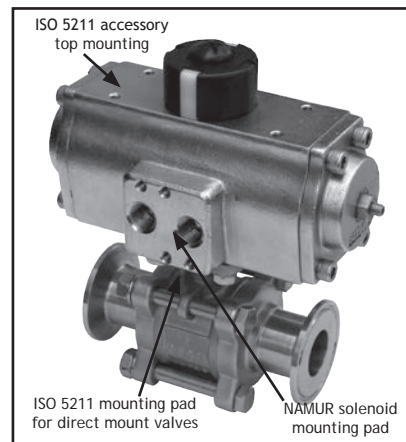
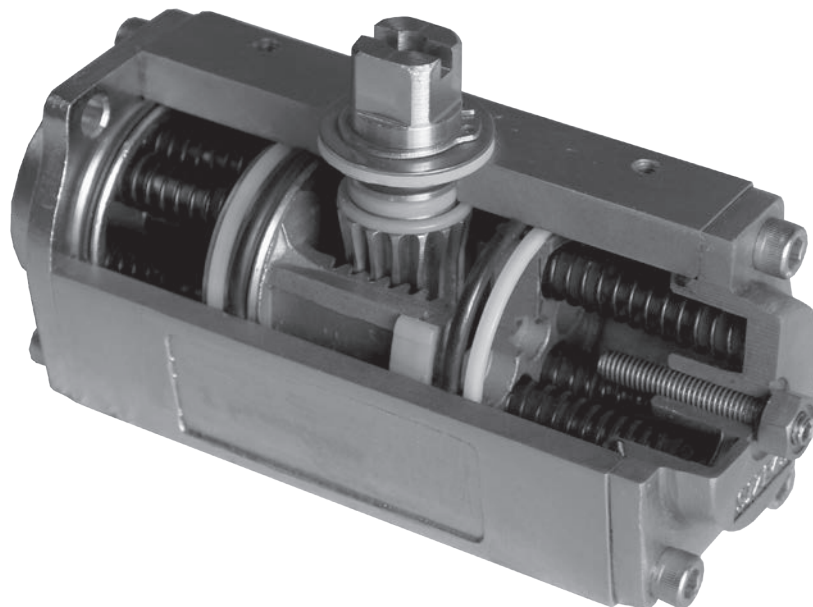

ACCESSORY MOUNTING

NAMUR and ISO mounting allows for the easy factory or field installation of solenoids, switches and positioners.

STAINLESS STEEL PISTONS

Durable, precision cast pistons provide full engagement with the pinion. Quality seals and guides provide high thrust stability with minimal friction.

TRAVEL STOPS

Travel adjustment of +/- 4° in the open position is standard on all models.

VALVE MOUNTING

ISO 5211 standard design provides direct mounting of most ISO pad valves, including BI-TORO® InstruPak ball and butterfly valves.

SPRING CARTRIDGES

The heavy duty spring cartridges allow for easy conversion of a double acting actuator to a spring return actuator, or to modify the torque output depending on air pressure.

NAMUR SHAFT

The slotted shaft, along with the NAMUR bolt pattern, allows for direct mounting of NAMUR standard switches and positioners.

SPRING COMBINATION OPTIONS



SPRING SET 02/40 PSI
(4 SPRINGS TOTAL)



SPRING SET 03/50 PSI
(6 SPRINGS TOTAL)



SPRING SET 06/100 PSI
(12 SPRINGS TOTAL)



SPRING SET 04/60 PSI
(8 SPRINGS TOTAL)



SPRING SET 05/80 PSI
(10 SPRINGS TOTAL)

SPRING SETS

All VNE SS series (stainless) pneumatic actuators come standard with a complete cartridge spring set (6 springs per side) sized for 80 PSI supply pressure unless otherwise specified. Actuators can be configured for different air supplies by removing springs from the end caps.

IMPORTANT: Springs must be arranged in a symmetrical manner (see arrangements to the left) so that side load does not occur between the pistons and the actuator body.

REVERSE OPERATION

All VNE actuators are set for a standard CW to close, CCW to open rotation. The action may be reversed by rotating the pistons 180°.

CAUTION: Refer to VNE operation and maintenance instructions before disassembly and removal of springs.

VNE BI-SS PARTS BREAKDOWN

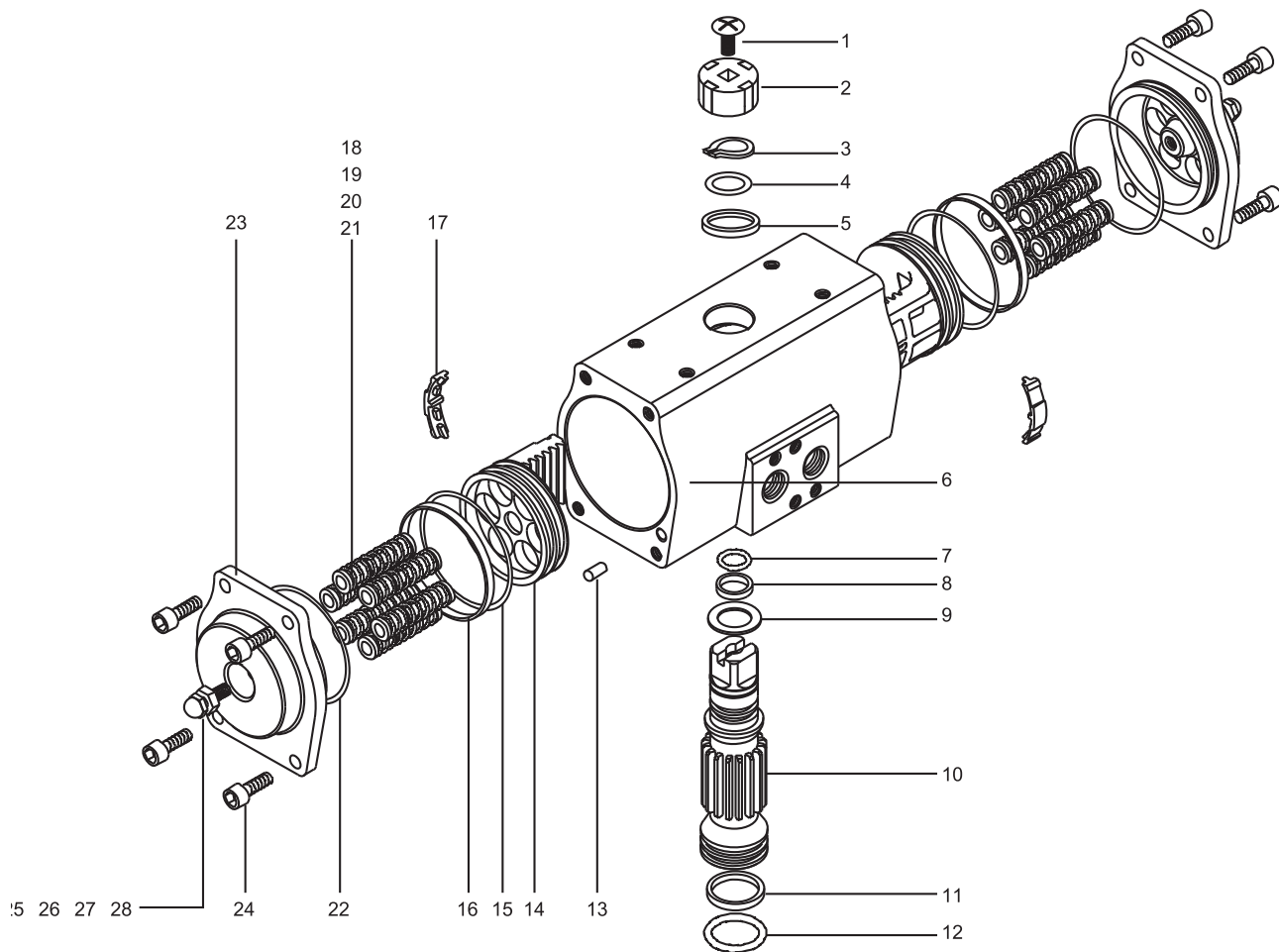

PART #	NAME	MATERIAL	QTY
1	BODY	SS	1
2	PISTON	SS	2
3	END CAPS	SS	2
4	PINION	SS	1
5	GUIDE BEARING	NYLON 6	1
6	PINION BEARING (TOP)	TFE	1
7	PINION BEARING (BOTTOM)	TFE	1
8	SNAP RING	SS	1
9	O-RING (INNER TOP)	VITON®	1
10	O-RING (OUTER TOP)	VITON®	1
11A	WASHER	SS	1
11B	BEARING	NYLON 6	1
12	O-RING (INNER BOTTOM)	VITON®	1
13	O-RING (OUTER BOTTOM)	VITON®	1
14	O-RING (PISTON)	VITON®	2

PART #	NAME	MATERIAL	QTY
15	PISTON BEARING	NYLON 6	2
16	O-RING (END CAP)	VITON®	2
17A	BOLTS (END CAP)	SS	8
17B	LOCK WASHER	SS	8
18	TRAVEL STOP	SS	2
19	O-RING (TRAVEL STOP)	VITON®	2
20A	WASHER	SS	2
20B	NUT (TRAVEL STOP)	SS	2
21	RETAINING NUT	SS	2
22	SPRING RETAINER	NYLON 6	*
23	SPRING	PLATED CS	*
24	SPRING	PLATED CS	*
25	SPRING SCREW	SS	*
26	SPRING NUT	SS	*
27	POSITION INDICATOR	NYLON	1
28	PORT PLUG	NYLON 6	2

VNE BI-SS DIMENSIONAL DATA

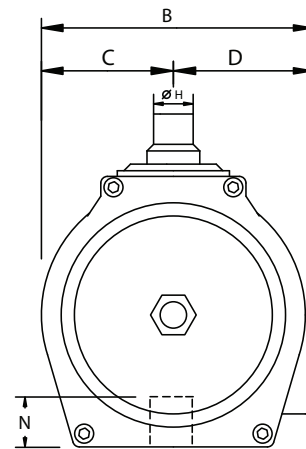
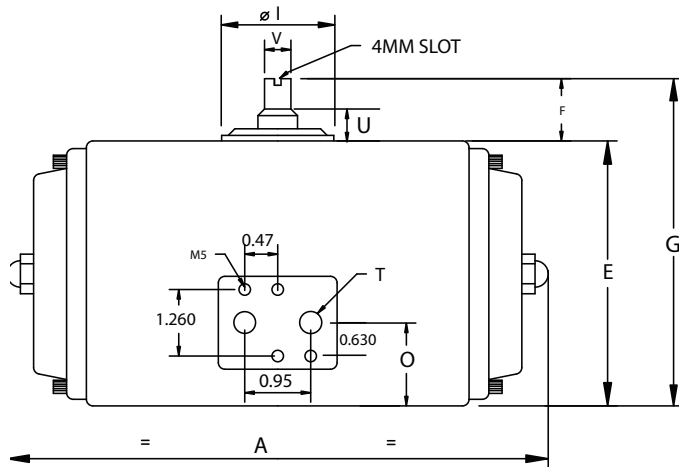
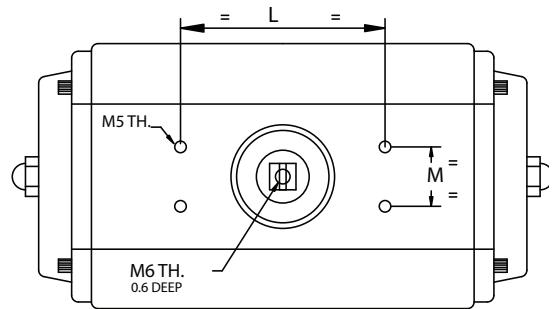
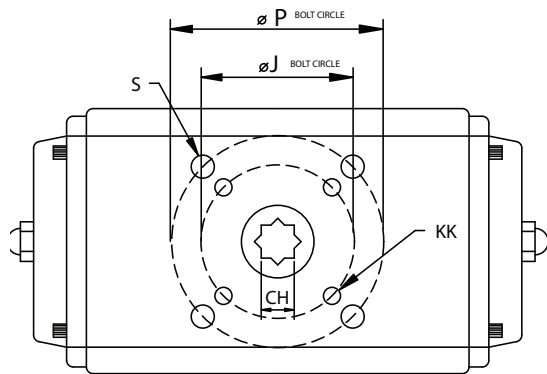

MODEL	A	B	C	D	E	F	G	CH	J
BI-45-SS	7.56	2.56	1.15	1.15	2.56	0.787	3.34	0.433	1.42
BI-60-SS	7.34	2.92	1.39	1.39	3.18	0.787	3.97	0.551	1.97
BI-85-SS	8.37	3.97	1.91	1.91	4.24	0.787	5.03	0.669	1.97
BI-105-SS	10.53	4.75	2.29	2.29	5.23	0.787	6.02	0.866	2.76
BI-125-SS	12.20	5.39	2.69	2.69	6.09	1.181	7.27	0.866	2.76
BI-140-SS	19.29	6.26	3.11	3.11	6.89	1.181	8.07	1.063	4.02
BI-160-SS	21.10	6.85	3.43	3.42	7.76	1.181	8.94	1.063	4.02

ACTUATOR WEIGHTS

MODEL	DA (LBS.)	SR (LBS.)
BI-45-SS	5.0	5.5
BI-60-SS	8.0	8.5
BI-85-SS	14	14.5
BI-105-SS	25.5	27.0
BI-125-SS	38.5	40.5
BI-140-SS	63.5	65.5
BI-160-SS	80.0	83.0

NOTE: Inserts and adapters are available for mounting to a variety of ISO and non-ISO mount valves.

MODEL	L	N	M	P	S	T	V	KK
BI-45-SS	3.15	0.58	1.181	1.97	M6 x 10	1/4" NPT	0.633	M5 x 8
BI-60-SS	3.15	0.59	1.181	N/A	M6 x 10	1/4" NPT	0.633	---
BI-85-SS	3.15	0.66	1.181	2.76	M8 x 13	1/4" NPT	0.635	M6 x 10
BI-105-SS	3.15	0.77	1.181	N/A	M8 x 13	1/4" NPT	0.629	---
BI-125-SS	5.12	0.97	1.181	4.02	M10 x 16	1/4" NPT	0.865	M8 x 13
BI-140-SS	5.12	1.18	1.181	4.92	M12 x 20	1/4" NPT	0.865	M10 x 16
BI-160-SS	5.12	1.18	1.181	4.92	M12 x 20	1/4" NPT	0.865	M10 x 16

VNE BI-SS ACTUATOR TORQUE CHARTS

SPRING RETURN TORQUE (IN. LBS)

	SPRINGS PER SIDE	SPRING TORQUE		40 PSI		60PSI		80PSI		100PSI	
MODEL	(5 STD)	END	BREAK	END	BREAK	END	BREAK	END	BREAK	END	BREAK
BI-45-SR-SS	3	35	57	14	36	50	72	86	108	121	143
	4	47	77			30	60	66	96	101	131
	5	60	96					47	83	82	118
	6	71	115							63	107
BI-60-SR-SS	3	67	136	35	104	120	189	206	275	291	360
	4	90	182			94	166	160	252	245	337
	5	119	207					125	230	200	315
	6	135	273							154	292
BI-85-SR-SS	3	167	273	106	203	282	388	467	573	652	758
	4	223	364			191	332	376	517	561	702
	5	279	430					284	461	429	646
	6	335	523							378	590
BI-105-SR-SS	3	346	574	65	278	362	590	675	903	987	1215
	4	461	766			170	475	483	788	795	1110
	5	576	956					293	673	605	985
	6	692	1141							420	869
BI-125-SR-SS	3	651	941	336	563	881	1171	1288	1778	1895	2385
	4	760	1222			689	953	1105	1560	1514	2167
	5	1080	1602					927	1349	1134	1956
	6	1301	1790							1153	1735
BI-140-SR-SS	3	808	1359	655	1226	1592	2243	2517	3260	3525	4277
	4	1071	2087			1200	1980	1983	2997	3166	4014
	5	1345	2607					1755	2623	2625	3740
	6	1610	3026							2340	3475
BI-160-SR-SS	3	1522	2098	895	1580	2420	3131	4022	4682	4657	6233
	4	2035	3133			1720	2618	3122	4169	4822	5720
	5	2550	3690					2467	3654	3588	5205
	6	3054	4893							3333	4701

DOUBLE ACTING TORQUE (IN. LBS)

MODEL	40PSI	60PSI	80PSI	100PSI	120PSI
BI-45-DA-SS	71	107	143	178	214
BI-60-DA-SS	171	256	342	427	512
BI-85-DA-SS	370	555	740	925	1110
BI-105-DA-SS	624	936	1249	1561	1873
BI-125-DA-SS	1214	1822	2429	3036	3643
BI-140-DA-SS	2034	3051	4068	5085	6102
BI-160-DA-SS	3102	4653	6204	7755	9306